

GEAR PUMPS

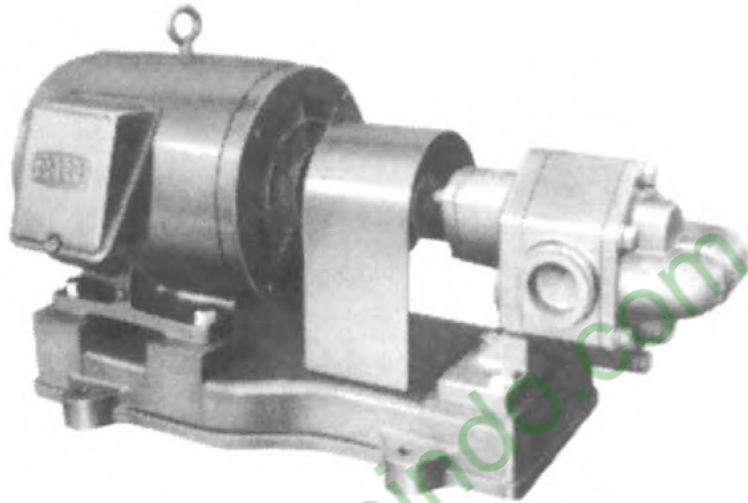

APPLICATIONS

- Supply oil for machinery
- Fuel transfer
- Low pressure transmission
- Oil burner injection

FEATURES

- **Compact style and light weight**
Adopting high speed and direct drive type, relieving traditional image of gear pumps.
- **Large capacity with small power output**
- **Long life and high reliability**
Durability increased by adopting needle bearings and maintenance made easy by using bearings, requiring no oil supply.
- **Quick delivery and low price**
- **Adjustable relief valve**

SPECIFICATIONS

MODEL		GPE	GPF
Liquid	Quality Temperature Viscosity	B.C. heavy oil, turbine oil, etc 0 - 70°C 7 - 500 centistoke	Heavy oil, turbine oil, etc 0 - 80°C 5 - 500 cst
Suction & Discharge size		12 to 25mm (³ / ₈ to 1 inch)	12 to 40mm (³ / ₈ to 1 1/2 inches)
Discharge pressure		3kgf/cm ² (43PSI) {290kPa}	3 to 10kgf/cm ² (43 to 142PSI) {290 to 980kPa}
Allowable suction pressure		- 0.3 to + 1.0kgf/cm ² (- 4.3 to +14.2PSI) {- 29 to + 98kPa}	- 0.5 to + 1.0kgf/cm ² (- 7.1 to +14.2PSI) {- 49 to + 98kPa}
Temperature limit		70°C (158°F)	80°C (176°F)
Viscosity range for motor with standard output & speed		7 to 500cSt {7 to 500mm ² /s}	5 to 500cSt {5 to 500mm ² /s}
Construction	Shaft seal Bearing	Gland packing Needle puller bearing	Mechanical seal Needle puller bearing
Connection		Screw-in	Screw-in
Material (JIS)	Casing Gear Shaft	FC200 S45C S45C	FC200 S45C S45C

PERFORMANCE TABLE

Model GPE (Discharge pressure 3kgf/cm² {290kPa})

Size	Pipe Connecting	Motor kW	50 Hz			60 Hz			Bearing size	Gland		Weight {Mass} kg	
			Max. Discharge pressure kgf/cm ² {kPa}	Capacity l/min	Speed min ⁻¹	Max. Discharge pressure kgf/cm ² {kPa}	Capacity l/min	Speed min ⁻¹		Kind	Shaft size	Bare pump	Pump w/motor & base
12	PT- ³ / ₈	0.2	3{290}	6	1500	3{290}	6	1800	8ø	Packing	8ø	2	18.4
15	PT- ¹ / ₂	0.4	3{290}	10	1500	3{290}	12	1800	12ø	"	11ø	2.1	19.2
20	PT- ³ / ₄	0.4	3{290}	20	1500	3{290}	24	1800	12ø	"	11ø	2.4	21.4
25	PT-1	0.75	3{290}	40	1500	3{290}	48	1800	15ø	"	14ø	4	35.1

Model GPF (Discharge pressure 3~10kgf/cm² {290~980kPa})

12	PT- ³ / ₈	0.2	4{390}	8.5	1500	4{390}	10	1800	(12ø With inside ring)	Mechanical seal	12ø	3.1	20.1
		0.4	10{980}	8.5	1500	10{980}	10	1800					23.1
15	PT- ¹ / ₂	0.4	4{390}	17	1500	4{390}	21	1800	(12ø With inside ring)	"	12ø	3.4	22.4
		0.75	10{980}	17	1500	10{980}	21	1800					33.4
20	PT- ³ / ₄	0.75	4{390}	31	1500	4{390}	37	1800	(20ø With inside ring)	"	20ø	6.0	37.3
		1.5	10{980}	31	1500	10{980}	37	1800					43.3
25	PT-1	1.5	6{590}	54	1500	6{590}	65	1800	(20ø With inside ring)	"	20ø	6.3	44.3
		2.2	10{980}	54	1500	10{980}	65	1800					61.5
32	PT-1 ¹ / ₄	2.2	4{390}	75	1500	4{390}	90	1800	(22ø With inside ring)	"	22ø	11	68
		3.7	10{980}	75	1500	10{980}	90	1800					77.2
40	PT-1 ¹ / ₂	2.2	6{590}	105	1500				(22ø With inside ring)	"	22ø	12	69
		3.7	10{980}	105	1500								79
		3.7				4{390}	125	1800					79
		5.5				10{980}	125	1800					116

REMARKS :

1. Pipe connections are Pipe Taper Thread (JISB0203) for Model GPE and GPF.
2. Base dimension is based on dimension of JEM 1180 Class E motor.
3. Rotating direction shall be clockwise viewed from motor side. Suction opening shall be located at left side and delivery opening at right side. The opposite structure shall be obtained by simple re-assembly work.
4. Model GPE adopts packing seal, while Model GPF adopts mechanical seal.
5. Needle bearings are used. Please be noticed to nominate bearings with inside rings for Model GPF in case of parts order.
6. Special parts for adjusting working pressure of relief valves for Model GPE and GPF are available upon special request.

DIMENSION

Model GPE

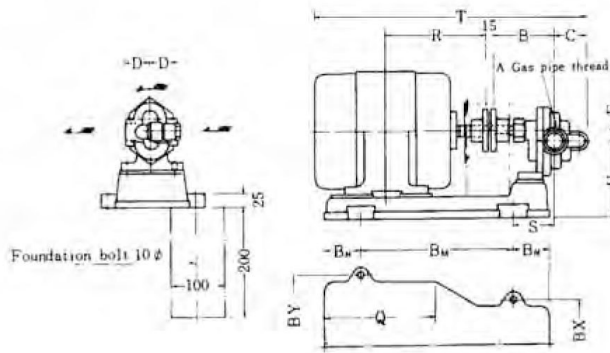

(DIMENSION IN : mm)

Size	Model	kW	A	B	C	D	F	BM	BN	BY	BX	R	S	T	U
12	GPEM	0.2	PT- ³ / ₈	90	50	40	12.5	160	60	180	138	103	64	370	90.5
15	GPEM	0.4	PT- ¹ / ₂	100	50	40	12	180	60	194	138	120	65	400	96
20	GPEM	0.4	PT- ³ / ₄	105	55	40	15	180	60	194	138	120	70	410	96
25	GPEM	0.75	PT-1	117	66	50	20	220	60	214	168	140	70	434	115

Model GPF

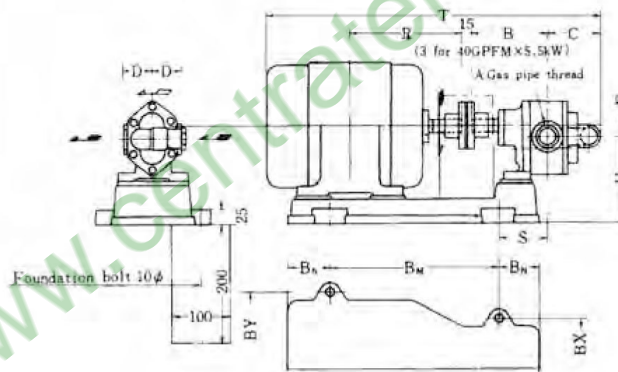

(DIMENSION IN : mm)

Size	Model	kW	A	B	C	D	F	BM	BN	BY	BX	R	S	T	U
12	GPFM	0.2	PT- ³ / ₈	98	60	40	15	160	60	180	138	103	63	388	96
		0.4						180	60	194	138	120	68	418	96
15	GPFM	0.4	PT- ¹ / ₂	103	65	40	15	180	60	194	138	120	68	418	96
		0.75						210	60	214	138	140	68	420	110
20	GPFM	0.75	PT- ³ / ₄	112	81	50	20	220	60	214	168	140	65	445	115
		1.5						260	60	232	168	168.5	65	492	115
25	GPFM	1.5	PT-1	120	89	50	20	260	60	232	168	168.5	73	508	115
		2.2						270	70	264	168	183	83	537	125
32	GPFM	2.2	PT-1 ¹ / ₄	156	102	60	25	280	80	264	194	183	95	586	145
		3.7						300	80	290	194	200	95	610	145
40	GPFM	2.2	PT-1 ¹ / ₂	162	108	60	25	280	80	264	194	183	101	598	145
		3.7						300	80	290	194	200	101	622	145
		5.5						310	90	320	194	239	111	665	162

STRAINERS

Model STU single strainer
(diameter 12 - 40 mm)

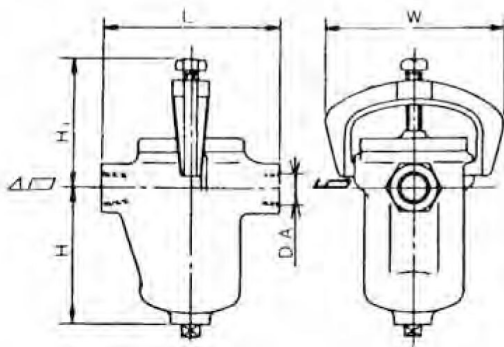

Model STW duplex strainer
(diameter 12 - 40 mm)

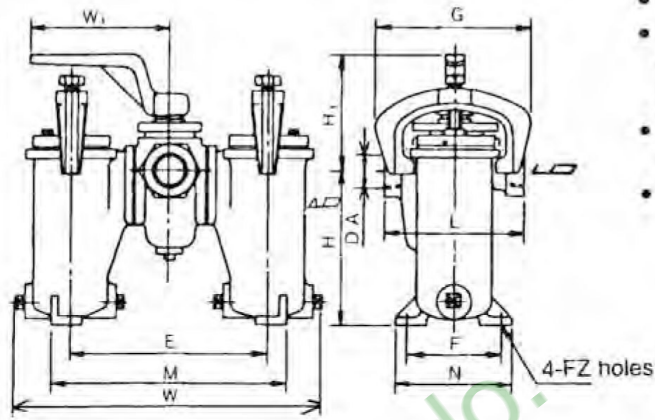

Specifications

- Mesh: 60
- Effective filtration area:
More than 8 times nominal inlet diameter
- Case hydro test pressure:
6 kgf/cm²
- Max. normal pressure:
3 kgf/cm²

Model	DA	L	H1	H	W	Weight kg
STU-12	PT- ³ / ₈	135	80	104	123	2.5
STU-15	PT- ¹ / ₂	120	80	104	123	2.5
STU-20	PT- ³ / ₄	170	105	155	154	4.0
STU-25	PT 1	150	105	155	154	4.0
STU-32	PT- ¹ / ₄	235	140	220	205	10.0
STU-40	PT- ¹ / ₂	210	140	220	205	10.0

Model	DA	L	G	H1	H	W1	W	E	F	M	N	FZ	Weight kg
STW-12	PT- ³ / ₈	135	-	83	92	120	234	125	90	165	110	12	7.0
STW-15	PT- ¹ / ₂	120	122	83	92	120	234	125	90	165	110	12	7.0
STW-20	PT- ³ / ₄	170	-	116	145	150	338	215	120	245	140	12	13.0
STW-25	PT 1	150	152	116	145	150	338	215	120	245	140	12	13.0
STW-32	PT- ¹ / ₄	175	177	156	195	215	375	249	249	281	150	15	18.0
STW-40	PT- ¹ / ₂	210	202	161	220	215	400	265	265	297	160	15	27.0

STU-50 (single): Flange JIS 10K

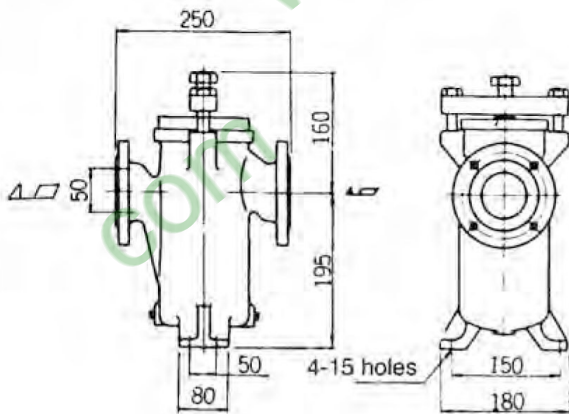

STW-50 (duplex): Flange JIS 10K

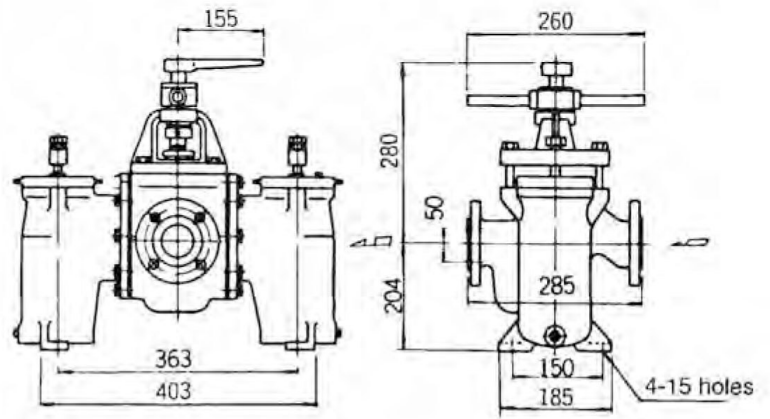

Direction of flow in model STW

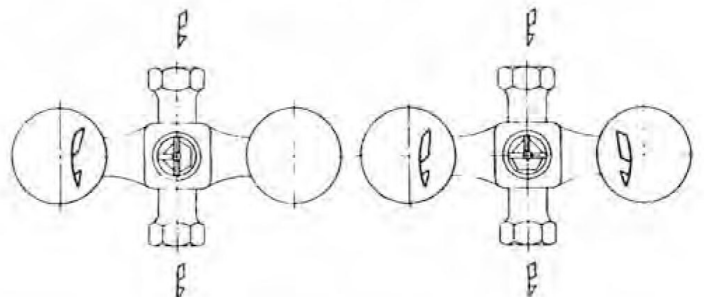

STRAINERS RESISTANCE CURVE

Model STU (single)

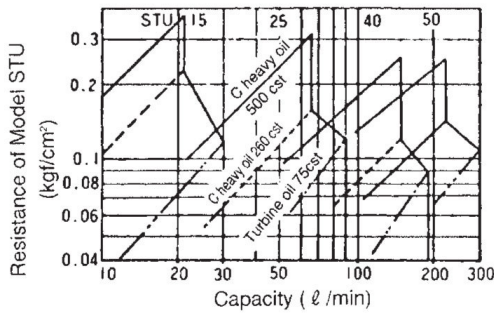

Model STW (duplex)

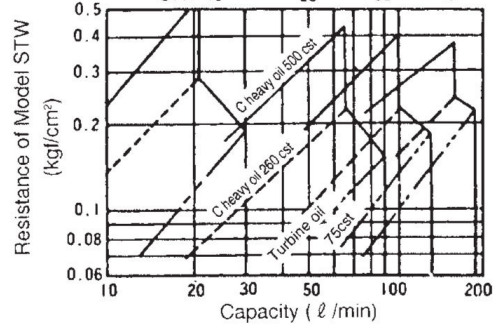

Notes:

1. The above resistance curves are approximate. Allow for variation of about 20%.
2. Be sure to take strainer resistance into account when considering pump suction capacity.
3. It is best if strainer resistance is less than 0.3 kgf/cm². If it exceeds this value, use a strainer one size larger and make suction pipes correspondingly thicker.
*1 kgf/cm² = 98.0665 kPa

OIL VISCOSITY CHART

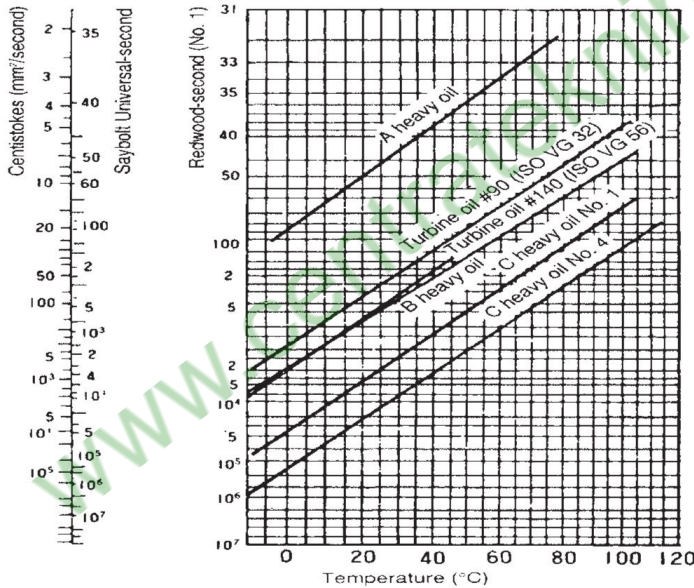

PIPING RESISTANCE

How to read the chart

1. Follow the line of the required capacity towards the right, till it meets the piping diameter line (on which diameter is marked in inches).
2. Move straight down from the meeting point of the lines, till you reach the reference line (indicated by an arrow).
3. Follow the diagonal line that runs through the point on the reference line (either upwards or downwards depending on the line) until you come to a (horizontal) viscosity (Redwood-seconds, RWS) line. Then drop a line straight downward from the intersection to the friction loss on the scale at the bottom of the chart, and read off the value.

Example:

1. When capacity is 100 m³/h, piping diameter is 6" and RWS is 2000, friction loss will be 0.1 kgf/cm² per 10m of piping
2. When capacity is 5 m³/h, piping diameter is 1" and RWS is 400, friction loss will be 1 kgf/cm² per 10m of piping

