

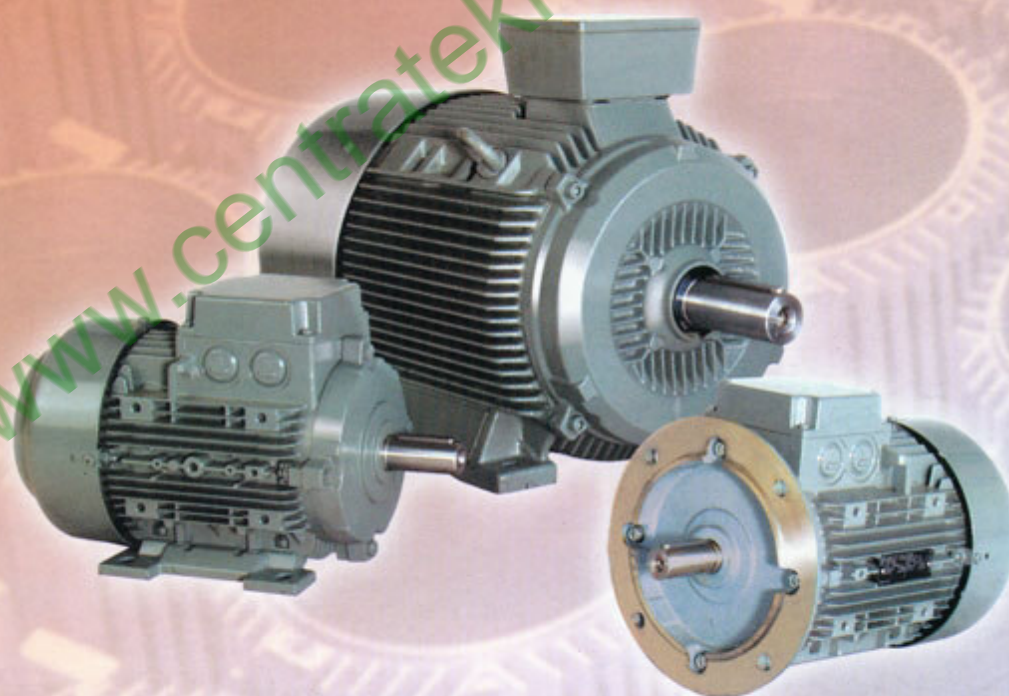

INDUCTION MOTORS



Series : 7AA, 7BA
14BG, 16BA

IP-55, Class F Insulation,
Frame No. 63 - 355
IEC Dimensions



Manufacturer :

SIEMENS
Elektromotory s.r.o.





The Manufacturer

Siemens Elektromotory s.r.o., the manufacturer of MEZ motors with two manufacturing plants in Czech Republic, Europe, is wholly owned and managed by Siemens AG group of Germany. It is part of Siemens AG's Standard Drive division currently based in Erlangen, at southern part of Germany.

Types of Motors

- MEZ motors, including series of 7AA/7BA, 16BA, C, 3AFP and 14BG, are manufactured and assembled in Europe and exported in completely built-up form with original packing to various countries in the world, including Indonesia.
- All the motors passed various tight tests and examinations during different production stages before arriving your factories.

General Specifications

- Voltages – Frequency – Power Output**
The 7AA series motors are delivered with either 220V D / 380V Y, 50Hz or 380V D / 660V Y, 50Hz as standard. The power output references are according to DIN 42673 and DIN 42677.
- Connections : Starting and Running**
Motors up to 3.7kW are suitable for direct-on-line starting. Larger motors are suitable for star-delta starting or starting by auto-transformers. Standard voltage at star (λ) connection is 380V and delta (Δ) connection is 220V, though other voltages are also available upon special request by customers.

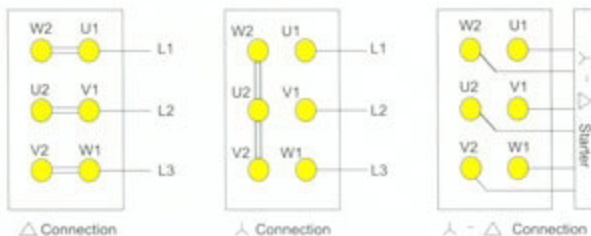

Siemens Elektromotory s.r.o., Plant Mohelnice, one of Siemens' manufacturing plants located in the city of Mohelnice, Czech Republic, produces MEZ Motors of frames 63 up to 160.

- Insulation**
Motor winding is of copper wire of insulation Class F, with temperature rise of Class B according to IEC 85 (CSN 33 0250). The winding can withstand a maximum temperature rise of 80°C at a maximum ambient temperature of 40°C.
- Enclosure**
Standard motors are of totally enclosed IP-55 enclosure in accordance with IEC 34-5 (EN 60034-5, CSN 350001) and thus water projected by a nozzle against the motor shall have no harmful effect. IP-56 enclosure is optional.

Designation	First Numeral	Second Numeral
IP-44	Protection against contact with live or moving parts inside the enclosure by tools, wires, or such objects of thickness greater than 1mm.	Water splashed against the machine from any direction shall have no harmful effect.
IP-54	Complete protection against contact with live or moving parts inside the enclosure.	Water splashed against the machine from any direction shall have no harmful effect.
IP-55	Protection against harmful deposits of dust. Dust cannot enter in an amount sufficient to interfere with operation.	Water projected by nozzle against the machine from any direction shall have no harmful effect.
IP-66	The ingress of dust is totally prevented from entering the internal part of body.	Water from heavy seas or water projected in powerful jets shall not enter the machine.

Operation & Environment

- ◆ **Operating Conditions**
Standard executions of the motors have been designed to operate at an ambient temperature ranging from -30°C up to +40°C and at an altitude of up to 1000 m above sea level.
- ◆ **Temperature and Altitude**
Operation at ambient temperature higher than 40°C or at altitude of more than 1,000 m above sea level would affect the actual output of the motors. Please refer to the tables on page No. 11 of this catalogue.

Mounting Arrangements

As standard, the following mounting arrangements can be delivered according to IEC 34-7 (EN 60034-7, CSN 60034-7) as shown in the table below :

Foot Mounted : IM 1081
Flange Mounted : IM 3041, IM 3641

FIGURES					
IEC 34-7	Code I	IM B3	IM V5	IM V6	IM B6
	Code II	IM 1001	IM 1011	IM 1031	IM 1051
		IM 1081			
FIGURES					
IEC 34-7	Code I	IM B7	IM B8	IM B5	IM V1
	Code II	IM 1061	IM 1071	IM B14	IM V18
		IM 1081		IM 3001	IM 3001
				IM 3601	IM 3601
		IM 3041 - 3641			
FIGURES					
IEC 34-7	Code I	IM V3	IM B35	IM V15	IM V36
	Code II	IM 3031	IM 2001	IM 2011	IM 2031
		IM 3631	IM 2001		
		IM 3041-3641			

Ordering Information:

Please provide us with following information of motors you need in your purchase order when placing an order to us :

- Type of motor (such as 7AA, 7BA, 14BG, 16BA, etc),
- Application and mounting (B3, B5, V1, etc),
- Output (in kW or Hp),
- Voltage, frequency of power source,
- Insulation class (B, F or H class),
- Protection Class (IP-54, 55 or 56),
- Type of starting (direct-on-line or λ - Δ starting),
- Type of drive (direct drive, V-Belt drive, etc),
- Indoor or outdoor use,
- Accessories (thermistors, space heaters, etc).

Models of Bearings

- ◆ The nominal bearing life for motors with horizontal mounting is at least 100.000 hours. The bearings of motors with frame sizes up to 250M are lubricated for life. Frame size 280S and larger sizes have regreasable facility with flat-type grease nipples.
- ◆ Regreasable bearings can be fitted to motors of frame sizes 180M to 250M under special request and with extra costs charged to customers. Each of the 14BG motors with frame size 180M or larger has located bearings at the non-drive and free bearings at the drive end - the larger is preloaded.

Frame Sizes	NDE Bearings	DE Bearings	Tapped Holes DE
56	6201	6201	M3x9
63	6201	6201	M 4 x 13
71	6202	6202	M5x12.5
80	6004	6004	M 6 x 16
90	6205	6004	M 8 x 19
100	6205 2Z	6206 2Z	M10x22
112	6205 2Z	6206 2Z	M10x22
132	6208 2Z	6208 2Z	M12x28
160	6209 2Z	6209 2Z	M16x36
180	6210 Z C3	6210 Z C3	M16x36
200	6212 Z C3	6212 Z C3	M20x42
225	6213 Z C3	6213 Z C3	M20x42
250	6215 Z C3	6215 Z C3	M20x42
280S	6217 Z C3	6217 C3	M20x42
280M	6317 C3	6317 C3	M20x42
315S	6219 C3	6219 C3	M20x42
315M	6319 C3	6319 C3	M20x42
315L (2P)	6219 C3	6219 C3	M20x42
315L (4-8P)	6319 C3	6319 C3	M20x42

Bearing Arrangements

Standard bearing designs are as below :

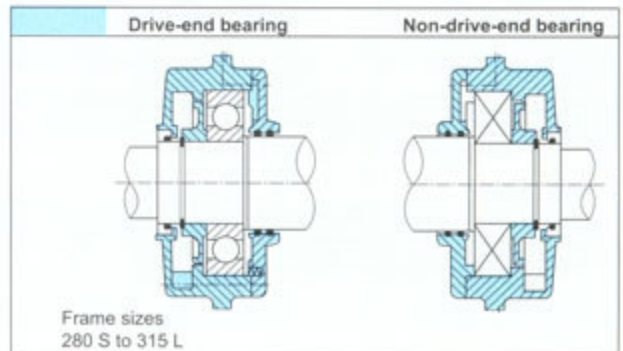
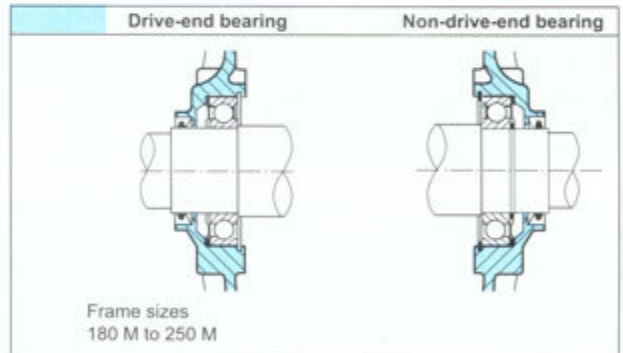

PERFORMANCE DATA

7AA & 7BA Series : 63 - 160L

2 POLE - 3000 RPM SYNCHRONOUS SPEED AT 380V, 50Hz

Motor Type	Output		Speed (RPM)	Efficiency η	COS ϕ	Stator Current at 380 V (A)		Nominal Torque (Nm)	Ts		Is		Tm		Weight (kg)		Moment of inertia (kg m ²)
	Hp	Kw				7AA	7BA		Tf	If	Tf	If	7AA	7BA			
63M02K	1/4	0.18	2820	63	0.82	0.54	-	0.61	2	3.7	2.2	3.5	-	0.00018			
63M02	1/3	0.25	2830	65	0.82	0.72	-	0.84	2	4	2.2	4.1	-	0.00023			
71M02K	1/2	0.37	2740	66	0.82	1.05	-	1.3	2.3	3.5	2.3	5	-	0.00035			
71M02	3/4	0.55	2800	71	0.82	1.43	-	1.9	2.5	4.3	2.6	6.6	-	0.00045			
80M02K	1	0.75	2855	73	0.86	1.82	-	2.5	2.3	5.6	2.4	8.2	-	0.00085			
80M02	1.5	1.1	2845	77	0.87	2.53	-	3.7	2.6	6.1	2.7	9.9	-	0.0011			
90S02	2	1.5	2860	78	0.85	3.47	-	5	2.4	5.5	2.7	12.9	-	0.0015			
90L02	3	2.2	2880	81	0.85	4.84	-	7.3	2.8	6.3	3.1	15.7	-	0.002			
100L02	4	3	2890	84	0.85	6.42	6.42	9.9	2.8	6.8	3	21.5	28	0.0038			
112M02	5.5	4	2905	85	0.87	8.21	8.21	13.1	2.6	7.2	2.9	29	39	0.0055			
112M02V	7.5	5.5	2900	86	0.87	11.27	-	18.1	2.6	7.5	3.4	37	-	0.0077			
132S02K	7.5	5.5	2915	84.5	0.9	11.69	11.37	18	2	5.5	2.8	40.5	51	0.016			
132S02	10	7.5	2915	86	0.91	15.48	14.74	24.4	2.3	6.3	3	48.5	58	0.021			
132M02V	15	11	2900	86	0.91	22.11	21.68	36.2	2.6	7.5	3.6	58	71.5	0.026			
160M02K	15	11	2915	87	0.9	22.32	21.58	36	1.9	6	2.8	68.5	91	0.034			
160M02	20	15	2925	88.5	0.9	29.68	28.95	49	2.2	6.4	3	76.5	100	0.04			
160L02	25	18.5	2935	90	0.91	36.21	35.06	60	2.6	7.1	3.4	87	110	0.052			

4 POLE - 1500 RPM SYNCHRONOUS SPEED AT 380V, 50Hz

Motor Type	Output		Speed (RPM)	Efficiency η	COS ϕ	Stator Current at 380 V (A)		Nominal Torque (Nm)	Ts		Is		Tm		Weight (kg)		Moment of inertia (kg m ²)
	Hp	Kw				7AA	7BA		Tf	If	Tf	If	7AA	7BA			
63M04	1/4	0.18	1350	60	0.77	0.59	-	1.3	1.9	3	1.9	4.1	-	0.0004			
71M04K	1/3	0.25	1350	60	0.79	0.80	-	1.8	1.9	3	1.9	4.8	-	0.0006			
71M04	1/2	0.37	1370	65	0.8	1.08	-	2.5	1.9	3.3	2.1	6	-	0.0008			
80M04K	3/4	0.55	1395	67	0.82	1.53	-	3.7	2.2	3.9	2.2	8	-	0.0015			
80M04	1	0.75	1395	72	0.81	1.96	-	5.1	2.3	4.2	2.3	9.4	-	0.0018			
90S04	1.5	1.1	1415	77	0.81	2.69	-	7.4	2.3	4.6	2.4	12.3	-	0.0028			
90L04	2	1.5	1420	79	0.81	3.58	-	10.1	2.4	5.3	2.6	15.6	-	0.0035			
100L04K	3	2.2	1420	82	0.82	4.95	4.95	14.8	2.5	5.6	2.8	21.5	28	0.0048			
100L04	4	3	1420	83	0.82	6.74	6.74	20.2	2.7	5.6	3	24.5	30	0.0058			
112M04	5.5	4	1440	85	0.83	8.63	8.63	26.5	2.7	6	3	31	40	0.011			
112M04V	7.5	5.5	1440	82	0.8	12.74	13.37	36.6	3.3	6.8	3.4	37	46	0.014			
132S04	7.5	5.5	1455	86	0.81	12.00	12.00	36.1	2.5	6.3	3.1	42.5	53	0.018			
132M04	10	7.5	1455	87	0.82	16.00	16.00	49.2	2.7	6.7	3.2	49	61	0.024			
160M04	15	11	1460	88.5	0.84	22.63	22.63	72	2.2	6.2	2.7	68	91	0.04			
160L04	20	15	1460	90	0.84	30.00	30.00	98.1	2.6	6.5	3	93.5	116.5	0.052			

6 POLE - 1000 RPM SYNCHRONOUS SPEED AT 380V, 50Hz

Motor Type	Output		Speed (RPM)	Efficiency η	COS ϕ	Stator Current at 380 V (A)		Nominal Torque (Nm)	Ts		Is		Tm		Weight (kg)		Moment of inertia (kg m ²)
	Hp	Kw				7AA	7BA		Tf	If	Tf	If	7AA	7BA			
71M06K	1/4	0.18	835	56	0.75	0.65	-	2.0	2.1	2.3	1.9	6.3	-	0.0006			
71M06	1/3	0.25	850	61	0.76	0.82	-	2.8	2.2	2.7	2	6.3	-	0.0009			
80M06K	1/2	0.37	920	62	0.72	1.25	-	3.9	1.9	3.1	2.1	7.5	-	0.0015			
80M06	3/4	0.55	910	67	0.74	1.63	-	5.8	2.1	3.4	2.2	9.4	-	0.0018			
90S06	1	0.75	915	69	0.76	2.21	-	8	2.2	3.7	2.2	12.5	-	0.0028			
90L06	1.5	1.1	915	72	0.75	3.05	-	12	2.3	3.8	2.3	15.7	-	0.0035			
100L06	2	1.5	925	74	0.75	4.11	4.21	15.5	2.2	4.2	2.4	22.5	29	0.0063			
112M06	3	2.2	940	78	0.78	5.47	6.05	22.3	2.2	4.6	2.5	26	35	0.011			
132S06	4	3	950	79	0.76	7.58	7.89	30.1	1.9	4.2	2.2	37.5	49	0.015			
132M06K	5.5	4	950	80.5	0.76	9.89	10.42	40.2	2.1	4.5	2.4	44	56	0.019			
132M06	7.5	5.5	950	83	0.76	13.47	14.63	55.3	2.3	5	2.6	52	64	0.025			
160M06	10	7.5	960	86	0.74	17.89	18.11	75	2	4.6	2.5	73.5	97	0.041			
160L06	15	11	960	87.5	0.74	25.79	25.79	109.4	2.3	4.8	2.6	94	118	0.049			

PERFORMANCE DATA
14BG Series : 180M - 315L (Energy Saving)
2 POLE - 3000 RPM SYNCHRONOUS SPEED AT 380V, 50Hz

Motor Type	Order Code	Output		Speed (RPM)	Efficiency η	COS φ	Stator Current at 380 V (A)	Nominal Torque (Nm)	Ts	Is	Tm	Weight (kg)	Moment of inertia (kg m ²)
		Hp	Kw						—	—	—		
									Tf	If	Tf		
180M	14BG183-2AA	30	22	2945	91.6	0.86	42.6	71	2.5	6.4	3.4	145	0.068
200L	14BG206-2AA	40	30	2950	91.8	0.88	56.8	97	2.3	6.5	3.0	205	0.129
200L	14BG207-2AA	50	37	2955	92.9	0.89	68.4	120	2.5	7.2	3.3	225	0.153
225M	14BG223-2AA	60	45	2960	93.6	0.88	83.2	145	2.4	6.7	3.1	285	0.217
250M	14BG253-2AB	75	55	2970	93.6	0.88	101.1	177	2.1	6.7	3.1	375	0.403
280S	14BG280-2AB	100	75	2975	94.5	0.88	136.8	241	2.5	7.5	3.1	500	0.715
280M	14BG283-2AB	125	90	2975	95.1	0.89	162.1	289	2.6	7.2	3.1	540	0.832
315S	14BG310-2AB	150	110	2982	94.6	0.88	200.0	352	2.4	7.2	3.1	720	1.19
315M	14BG313-2AB	175	132	2982	95.1	0.90	236.8	423	2.4	6.9	3.0	775	1.39
315L	14BG316-2AB	220	160	2982	95.5	0.91	278.9	512	2.4	7.0	3.0	900	1.62
315L	14BG317-2AB	270	200	2982	95.9	0.92	342.1	641	2.3	6.7	2.9	1015	2.09

4 POLE - 1500 RPM SYNCHRONOUS SPEED AT 380V, 50Hz

Motor Type	Order Code	Output		Speed (RPM)	Efficiency η	COS φ	Stator Current at 380 V (A)	Nominal Torque (Nm)	Ts	Is	Tm	Weight (kg)	Moment of inertia (kg m ²)
		Hp	Kw						—	—	—		
									Tf	If	Tf		
180M	14BG183-4AA	25	18.5	1465	90.4	0.84	36.8	121	2.4	6.7	3.1	140	0.099
180L	14BG186-4AA	30	22	1465	91.0	0.84	43.7	143	2.5	6.9	3.2	155	0.117
200L	14BG207-4AA	40	30	1465	91.6	0.85	58.9	196	2.5	6.7	3.4	205	0.191
225S	14BG220-4AA	50	37	1475	92.2	0.85	71.6	240	2.5	6.7	3.1	265	0.374
225M	14BG223-4AA	60	45	1475	93.1	0.86	85.3	291	2.7	7.2	3.2	300	0.447
250M	14BG253-4AA	75	55	1480	93.5	0.85	105.3	355	2.4	6.1	2.8	390	0.688
280S	14BG280-4AA	100	75	1485	94.2	0.85	136.8	482	2.5	7.1	3.0	535	1.19
280M	14BG283-4AA	125	90	1485	94.6	0.86	168.4	579	2.5	7.4	3.0	580	1.39
315S	14BG310-4AA	150	110	1488	94.6	0.85	208.4	706	2.5	6.4	2.8	730	1.94
315M	14BG313-4AA	175	132	1488	95.2	0.85	247.4	847	2.7	6.8	2.9	810	2.31
315L	14BG316-4AA	220	160	1486	95.7	0.86	294.7	1028	2.7	6.8	2.8	955	2.88
315L	14BG317-4AA	270	200	1486	95.9	0.88	357.9	1285	2.6	6.5	2.8	1060	3.46

6 POLE - 1000 RPM SYNCHRONOUS SPEED AT 380V, 50Hz

Motor Type	Order Code	Output		Speed (RPM)	Efficiency η	COS φ	Stator Current at 380 V (A)	Nominal Torque (Nm)	Ts	Is	Tm	Weight (kg)	Moment of inertia (kg m ²)
		Hp	Kw						—	—	—		
									Tf	If	Tf		
180L	14BG186-6AA	20	15	965	88.9	0.83	31.1	148	2.3	5.3	2.5	150	0.175
200L	14BG206-6AA	25	18.5	975	89.8	0.81	38.4	181	2.5	5.6	2.5	195	0.238
200L	14BG207-6AA	30	22	975	90.3	0.81	45.8	215	2.6	5.7	2.5	205	0.287
225M	14BG223-6AA	40	30	978	91.8	0.83	60.0	293	2.7	5.6	2.5	280	0.492
250M	14BG253-6AA	50	37	980	92.3	0.83	73.7	361	2.7	6.0	2.3	370	0.762
280S	14BG280-6AA	60	45	985	92.4	0.85	87.4	436	2.4	6.1	2.4	475	1.12
280M	14BG283-6AA	75	55	985	92.7	0.86	105.3	533	2.5	6.3	2.5	510	1.37
315S	14BG310-6AA	100	75	988	93.5	0.84	145.3	725	2.5	6.5	2.8	685	2.10
315M	14BG313-6AA	125	90	988	93.9	0.84	172.6	870	2.6	6.8	2.9	750	2.50
315L	14BG316-6AA	150	110	988	94.3	0.86	206.3	1063	2.5	6.8	2.9	890	3.20
315L	14BG317-6AA	175	132	988	94.8	0.86	247.4	1276	3.1	7.3	3.0	980	4.02

PERFORMANCE DATA
14BG-S Series : 180L - 315L (Increased Rated Output)

2 POLE - 3000 RPM SYNCHRONOUS SPEED AT 380V, 50Hz

Motor Type	Order Code	Output Hp	Output Kw	Speed (RPM)	Efficiency η	COS ϕ	Stator Current at 380 V (A)	Nominal Torque (Nm)	Ts	Is	Tm	Weight (kg)	Moment of inertia (kg m ²)
									Tf	If	Tf		
180L	14BG188-2AA	40	30	2950	92.8	0.86	56.8	97	2.4	7.1	3.4	175	0.086
200L	14BG208-2AA	60	45	2955	93.6	0.89	82.1	145	2.5	6.9	3.2	255	0.182
225M	14BG228-2AA	75	55	2960	94.8	0.89	98.9	177	2.6	7.3	3.2	335	0.266
250M	14BG258-2AA	100	75	2970	94.5	0.88	136.8	241	2.4	7.1	3.1	420	0.483
280M	14BG288-2AB	150	110	2975	95.5	0.90	193.7	353	2.5	7.0	3.0	630	1.00
315L	14BG318-2AB	335	250	2982	96.0	0.92	431.5	801	2.4	6.7	2.8	1230	2.46
315L	14BG319-2AA	420	315	2986	96.4	0.89	557.9	1007	3.4	9.2	3.8	1350	2.78

4 POLE - 1500 RPM SYNCHRONOUS SPEED AT 380V, 50Hz

Motor Type	Order Code	Output Hp	Output Kw	Speed (RPM)	Efficiency η	COS ϕ	Stator Current at 380 V (A)	Nominal Torque (Nm)	Ts	Is	Tm	Weight (kg)	Moment of inertia (kg m ²)
									Tf	If	Tf		
180L	14BG188-4AA	40	30	1465	91.7	0.80	62.1	196	2.6	6.3	2.9	180	0.144
200L	14BG208-4AA	50	37	1465	92.5	0.83	73.7	241	2.6	6.5	3.0	230	0.234
225M	14BG228-4AA	75	55	1475	93.4	0.86	104.2	356	2.5	6.5	2.7	330	0.486
250M	14BG258-4AA	100	75	1482	94.3	0.85	143.2	483	2.5	7.0	3.0	460	0.856
280M	14BG288-4AA	150	110	1488	95.2	0.84	208.4	706	2.8	7.9	3.3	680	1.71
315L	14BG318-4AA	335	250	1488	96.1	0.87	452.6	1605	3.1	7.7	3.2	1290	4.22
315L	14BG319-4AA	420	315	1488	96.1	0.86	578.9	2022	3.4	7.7	3.1	1500	5.00

6 POLE - 1000 RPM SYNCHRONOUS SPEED AT 380V, 50Hz

Motor Type	Order Code	Output Hp	Output Kw	Speed (RPM)	Efficiency η	COS ϕ	Stator Current at 380 V (A)	Nominal Torque (Nm)	Ts	Is	Tm	Weight (kg)	Moment of inertia (kg m ²)
									Tf	If	Tf		
180L	14BG188-6AA	25	18.5	970	89.6	0.80	39.5	182	2.3	4.9	2.4	175	0.203
200L	14BG208-6AA	40	30	975	90.9	0.80	63.2	294	2.6	5.8	2.6	245	0.362
225M	14BG228-6AA	50	37	978	92.2	0.83	73.7	361	2.5	5.9	2.8	325	0.624
250M	14BG258-6AA	60	45	982	93.3	0.83	88.4	438	2.7	6.3	2.3	405	0.934
280M	14BG288-6AA	100	75	985	93.8	0.85	143.2	727	3.0	6.8	2.8	570	1.65
315L	14BG318-6AA	220	160	988	95.0	0.86	300.0	1547	3.0	7.5	3.0	1180	4.71
315L	14BG319-6AA	270	200	990	95.6	0.84	378.9	1929	2.9	7.5	3.2	1400	5.72

TEFC, Squirrel Cage Rotor, Fully Tropicalised
Series : 7AA & 7BA (Frame : 63 - 90)



7AA63M04 (4P - 0.25HP), B3



7AA63M04 (4P - 0.25HP), B5



7AA90L04 (4P - 2HP), B3



7AA90L04 (4P - 2HP), B5

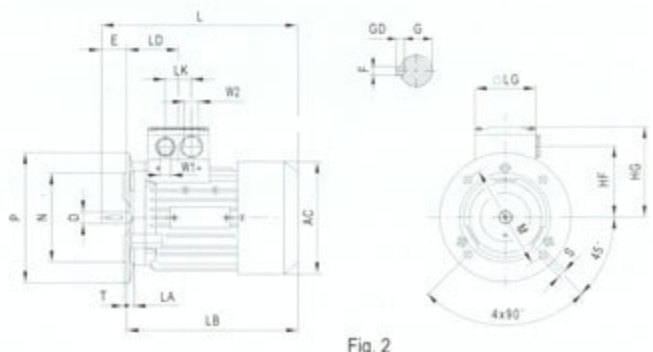
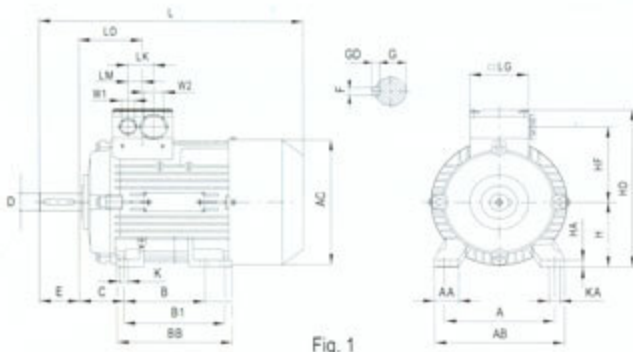

TEFC, Squirrel Cage Rotor, Fully Tropicalised
Series : 7AA & 7BA (Frame : 100 - 160L)



7AA100L04K (4P - 3HP), B3



7AA100L04K (4P - 3HP), B5



7AA112M04 (4P - 5.5HP), B3



7AA112M04 (4P - 5.5HP), B5

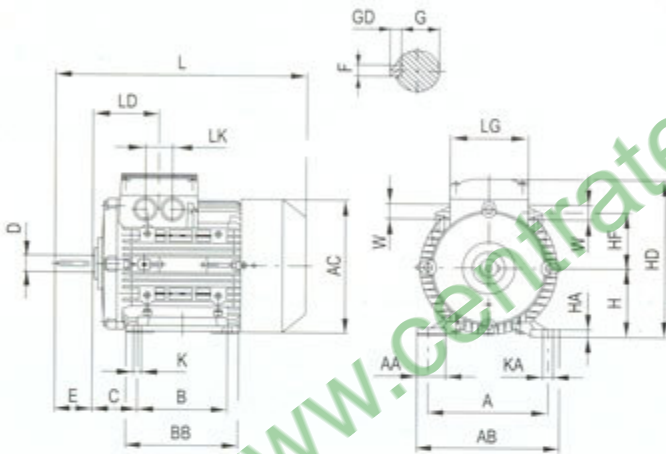

Fig. 3

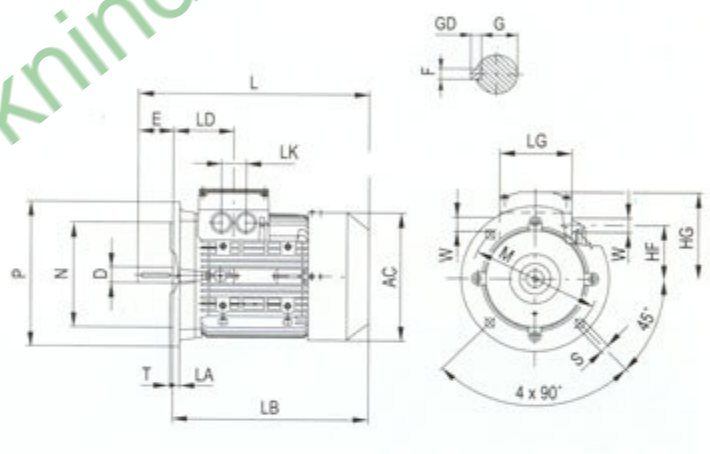

Fig. 4

7AA & 7BA Series, Frame : 63 - 160 L

DIMENSIONS (mm)

Frame	Fig.	A	AA	AB	AC	B	B1	BB	C	D	H	HA	HD	HF	K	KA	L
63	1, 2	100	27	120	118	80	-	96	40	11	63	7	164	77.5	7	10	202.5
71	1, 2	112	30.5	132	139	90	-	106	45	14	71	7	182	87.5	7	10	240
80	1, 2	125	30.5	150	156.5	100	-	118	50	19	80	8	200	96.5	9.5	13.5	273.5
90	1, 2	140	30.5	165	173.6	100	125	143	56	24	90	10	218	104.5	10	14	331
100 L	3, 4	160	42	196	196	140	-	176	63	28	100	12	234	78	12	16	372
112 M	3, 4	190	46	226	219.5	140	-	176	70	28	112	12	259	91	12	16	393
132 S	3, 4	216	53	256	259	140	-	180	89	38	132	15	296	107	12	16	454
132 M	3, 4	216	53	256	259	178	-	218	89	38	132	15	296	107	12	16	454
160 M	3, 4	254	60	300	314	210	-	256	108	42	160	18	351	127	15	19	588
160 L	3, 4	254	60	300	314	254	-	300	108	42	160	18	351	127	15	19	588

LD	LG	LK	W1/W2	W	E	F	G	GD	HG	LA	LB	M	N	P	S	T
69.5	75	32	M16/M25	-	23	4	8.5	4	101	8	179.5	115	95	140	10	3
63.5	75	32	M16/M25	-	30	5	11	5	111	9	210	130	110	160	10	3.5
63.5	75	32	M16/M25	-	40	6	15.5	6	120	10	233.5	165	130	200	12	3.5
79	75	32	M16/M25	-	50	8	20	7	128	10	281	165	130	200	12	3.5
102	120	42	-	32.3	60	8	24	7	134	11	312	215	180	250	14.5	4
102	120	42	-	32.3	60	8	24	7	147	11	333	215	180	250	14.5	4
128.5	140	42	-	32.3	80	10	33	8	164	12	374	265	230	300	14.5	4
128.5	140	42	-	for M32	80	10	33	8	164	12	374	265	230	300	14.5	4
160.5	165	54	-	for M40	110	12	37	8	191	13	478	300	250	350	18.5	5
160.5	165	54	-	40.3	110	12	37	8	191	13	478	300	250	350	18.5	5

TEFC, Squirrel Cage Rotor, Fully Tropicalised
Series : 14BG & 14BG-S (Frame : 180 - 250)



14BG186-4AA (4P - 30HP), B3



14BG183-4AA (4P - 25HP), B5



14BG253-4AA (4P - 75HP), B5

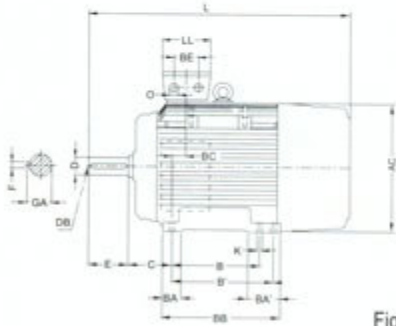

Fig. 5

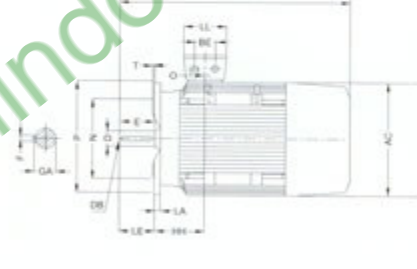
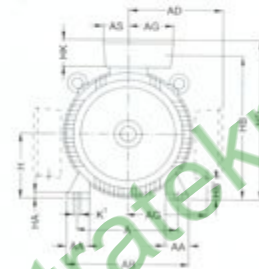
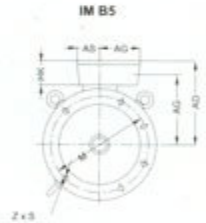

Fig. 6



14BG & 14BG-S Series, Frame Sizes : 180M - 250M

DIMENSIONS (mm)

Frame Sizes	Fig.	Type 14 BG	No. Poles	B	B'	A	HA	BB	AB	AC	H	L	BA	BA'	AA	HD	AD	AG	AS	K	K'	O	HB
180M	5, 6	...183	2 and 4	241*	279	279	20	328	340	364	180	670	50	91	65	442	262	81	71	15	19	M40x1.5	400
180L	5, 6	...186	4 to 8	241	279*	279	20	328	340	364	180	670	50	91	65	442	262	81	71	15	19	M40x1.5	400
		...188	2 to 8	241	279*	279	20	328	340	364	180	720	50	91	65	442	262	81	71	15	19	M40x1.5	400
200L	5, 6	...206	2 and 6	305		318	25	355	380	402	200	720	60	60	70	500	300	164	96	19	25	M50x1.5	447
		...207	2 to 8	305		318	25	355	380	402	200	720	60	60	70	500	300	164	96	19	25	M50x1.5	447
		...208	2 and 6	305		318	25	355	380	402	200	777	60	60	70	500	300	164	96	19	25	M50x1.5	447
			4 and 8								720												
225S	5, 6	...220	4 and 8	286*	311	356	34	361	436	445	225	790	85	110	80	550	325	164	96	19	25	M50x1.5	500
225M	5, 6	...223	2	286	311*	356	34	361	436	445	225	760	85	110	80	550	325	164	96	19	25	M50x1.5	500
			4 to 8								790												
		...228	2	286	311*	356	34	361	436	445	225	820	85	110	80	550	325	164	96	19	25	M50x1.5	500
			4 to 8								850												
250M	5, 6	...253	2	349		406	40	409	490	495	250	890	100	100	100	642	392	183	117	24	30	M63x1.5	558
			4 to 8																				
		...258	2	349		406	40	409	490	495	250	890	100	100	100	642	392	183	117	24	30	M63x1.5	558
			4									960											
			6 and 8									890											

Frame Sizes	HB'	C	BE	LL	BC	HK	AG'	D	DB	E	GA	F	P	N	LA	M	T	LE	S	Z	HH	AD	AH
180M	99	121	54	132	36	79	220	48	M16	110	51,5	14	350	250	13	300	5	110	18	4	157	262	452
180L	99	121	54	132	36	79	220	48	M16	110	51,5	14	350	250	13	300	5	110	18	4	157	262	452
	99	121	54	132	36	79	220	48	M16	110	51,5	14	350	250	13	300	5	110	18	4	157	262	452
200L	36	133	85	192	63	101	247	55	M20	110	59	16	400	300	15	350	5	110	18	4	196	300	486
	36	133	85	192	63	101	247	55	M20	110	59	16	400	300	15	350	5	110	18	4	196	300	486
	36	133	85	192	63	101	247	55	M20	110	59	16	400	300	15	350	5	110	18	4	196	300	486
225S	61	149	85	192	47	101	272	60	M20	140	64	18	450	350	16	400	5	140	18	8	196	325	556
225M	61	149	85	192	47	101	272	55	M20	110	59	16	450	350	16	400	5	110	18	8	196	325	556
								60	M20	140	64	18						140					
	61	149	85	192	47	101	272	55	M20	110	59	16	450	350	16	400	5	110	18	8	196	325	556
								60	M20	140	64	18						140					
250M	68	168	110	236	69	142	310	60	M20	140	64	18	550	450	18	500	5	140	18	8	237	392	620
								65	M20	140	69	18											
	68	168	110	236	69	142	310	60	M20	140	64	18	550	450	18	500	5	140	18	8	237	392	620
								65	M20	140	69	18											
								65	M20	140	69	18											
								65	M20	140	69	18											

TEFC, Squirrel Cage Rotor, Fully Tropicalised
Series : 14BG & 14BG-S (Frame : 280S - 315L)



14BG280-4AA (4P - 100HP), B3



14BG283-4AA (4P - 125HP), B5



14BG313-4AA (4P - 175HP), B3

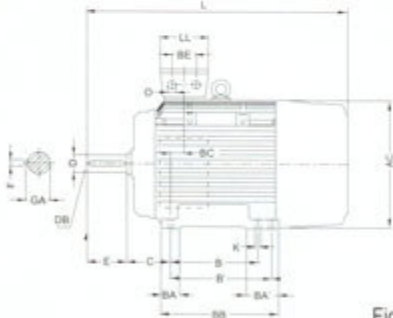

Fig. 7

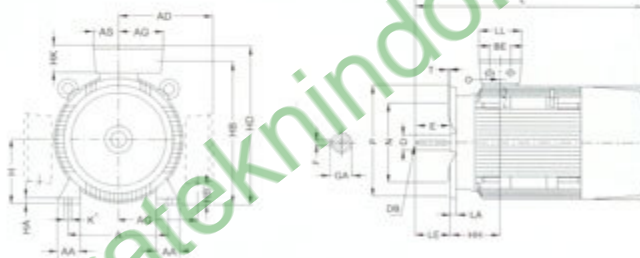
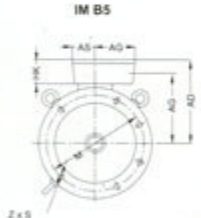

Fig. 8



14BG & 14BG-S Series, Frame Sizes : 280S - 315L

DIMENSIONS (mm)

Frame Sizes	Fig.	Type 14 BG	No. Poles	B	B'	A	HA	BB	AB	AC	H	L	BA	BA'	AA	HD	AD	AG	AS	K	K'	O	HB
280S	7, 8	280	2	368*	419	457	40	479	540	555	280	960	100	151	100	712	432	182	118	24	30	M63x1.5	628
			4 to 8																				
280M	7, 8	283	2	368	419*	457	40	479	540	555	280	960	100	151	100	712	432	182	118	24	30	M63x1.5	628
			4 to 8																				
		288	2	368	419*	457	40	479	540	555	280	1070	100	151	100	712	432	182	118	24	30	M63x1.5	628
			4																				
			6 and 8									960											
315S	7, 8	310	2	406*	457	508	50	527	610	610	315	1072	125	176	120	815	500	226	154	28	35	M63x1.5	715
			4 to 8									1102											
315M	7, 8	313	2	406	457*	508	50	527	610	610	315	1072	125	176	120	815	500	226	154	28	35	M63x1.5	715
			4 to 8									1102											
315L	7, 8	316/317	2	457	508*	508	50	578 ⁽¹⁾	610	610	315	1232	125	176	120	815	500	226	154	28	35	M63x1.5	715
			4 to 8									1262											
		318	8																				
		318	6	406	457	508	30	666	610	610	315	1402	125	176	120	815	500	226	154	28	35	M63x1.5	715
		319	4									1402											
			2	406	457	508	30	666	610	610	315	1372	155	250	120	967	652	310	165	28	25	M72x2	836
			4									625											
			6 and 8									1486											

Frame Sizes	HB'	C	CA	CA'	BE	LL	BC	HK	AG'	D	DB	E	GA	F	P	N	LA	M	T	LE	S	Z	HH	AD	AH
280S	98	190	267	216	110	236	62	142	348	65	M20	140	69	18	550	450	18	500	5	140	18	8	252	432	672
										75	M20	140	79.5	20											
280M	98	190	267	216	110	236	62	142	348	65	M20	140	69	18	550	450	18	500	5	140	18	8	252	432	672
										75	M20	140	79.5	20											
	98	190	377	326	110	236	62	142	348	65	M20	140	69	18	550	450	18	500	5	140	18	8	252	432	672
										75	M20	140	79.5	20											
			267	216						75	M20	140	79.5	20											
315S	89	216	315	264	110	307	69	170	400	65	M20	140	69	18	660	550	22	600	6	140	22	8	285	500	780
										80	M20	170	85	22											
315M	89	216	315	264	110	307	69	170	400	65	M20	140	69	18	660	550	22	600	6	140	22	8	285	500	780
										80	M20	170	85	22											
315L	89	216	424	373	110	307	69	170	400	65	M20	140	69	18	660	550	22	600	6	140	22	8	285	500	780
										80	M20	170	85	22											
										80	M20	170	85	22											
	89	216	615	564	110	307	69	170	400	80	M20	170	85	22	660	550	22	600	6	170	22	8	285	500	780
										85 ⁽²⁾	M20	170	90	22											
	5	216	615	564	135	330	69	322	521	65	M20	140	69	18	800	680	25	740	6	170	22	8	345	652	780
			759	708						85 ⁽²⁾	M20	170	90	22											
			699	648			69			85 ⁽³⁾	M20	170	90	22											

Accessories and spare parts

Frame sizes 180M to 250M
14BG, 16BG



Frame sizes 280S to 315M
14BG, 16BG

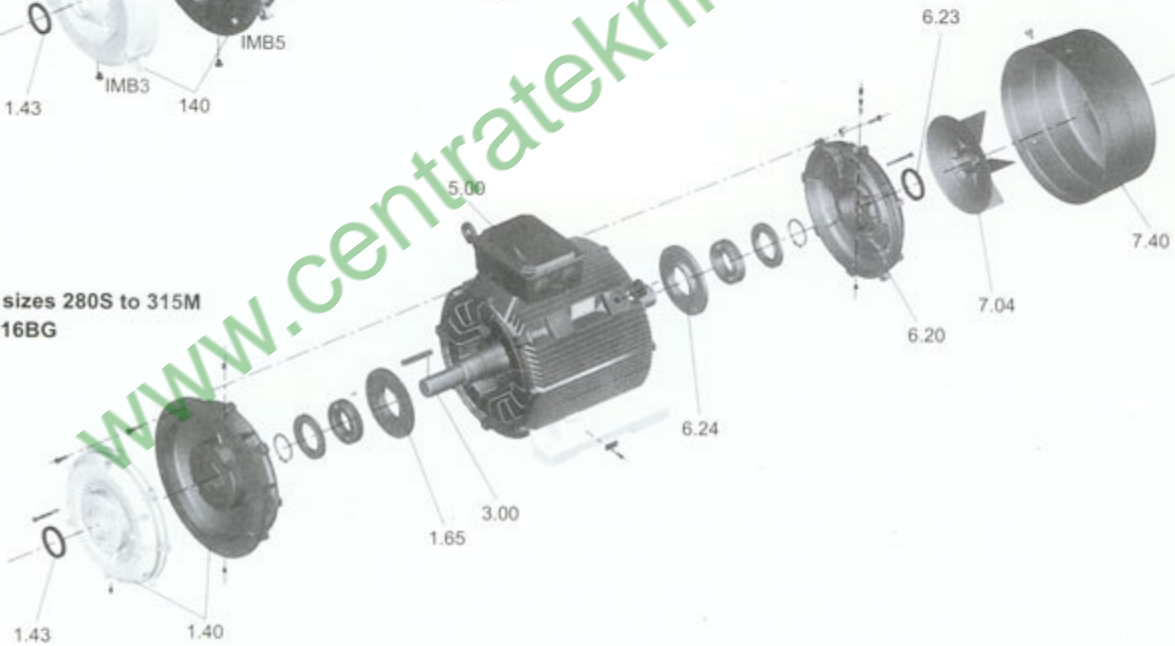

Terminal Boxes

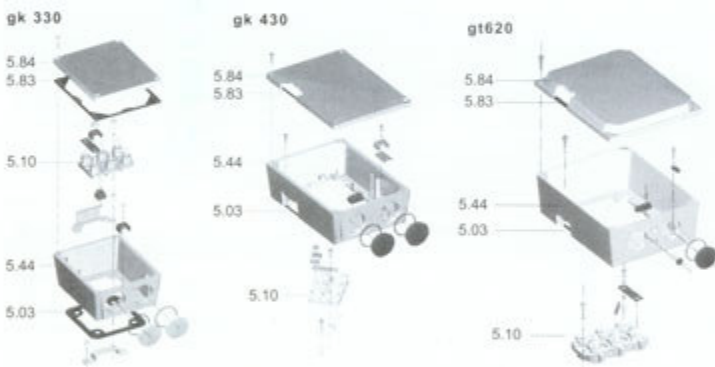

Part No.	Part Names
1.40	Endshield (bracket)
1.43	Shaft sealing ring
1.65	Cover of bearing
1.67	Outer bearing cap
3.00	Rotor, complete
4.07	Body footing
5.00	Terminal box, complete
5.03	Gasket
5.10	Terminal board, complete
5.44	Upper part of terminal box
5.83	Gasket
5.84	Cover for terminal box
6.20	Endshield (bracket)
6.23	Shaft sealing ring
6.24	Cover of bearing
6.26	Outer bearing cup
7.04	Fan
7.40	Fan cover

BASIC DESIGN FEATURES OF STANDARD LOW VOLTAGE MOTORS

SERIES : 7AA / 7BA, Frame Sizes 56 to 160

MEZ SAFE and SAVE types, 7AA / 7BA series motors, in frame sizes 56 to 160, are three-phase squirrel-cage induction motors with standard IP-55 protection, in accordance with IEC-34-5 (EN 60034-5, CSN 350001).

Oil seals can be provided on request if higher grade of protection against oil penetration is required.

Motor windings are of copper wires of insulation Class F, according to IEC 85 (CSN 33 0250).

Output and other specifications of the motors comply with IEC 34-1.

- ❑ Motor frames are of die-cast aluminium for 7AA size 56 to 160, while 7BA size 100 to 160 are of cast iron.
- ❑ Foot mounted motors of frame size 56 to 90 have feet cast on the body, and size 100 to 160 have feet of bolt-on design.
- ❑ The whole terminal boxes, including terminal box lids, are produced from die-cast aluminium for size 56 to 90, where as terminal box lids of standard cast-on terminal boxes for size 100 to 160 are made of aluminium.
- ❑ All terminal boxes are located on top as standard. Cable entries rotate by either 90° or 180°.
- ❑ End shields (brackets) are made of grey cast iron.
- ❑ Fans are plastic, fan covers are made of steel sheet.
- ❑ Motor winding is of copper wire of insulation Class F with temperature rise of Class B according to IEC 85.
- ❑ Rotor cage is made of die-cast aluminium. The rotor lamination stack is pressed onto the shaft, dynamically balanced with half-key and fitted with ball bearings.
- ❑ The motors are fitted with one protective mounting terminal situated in the terminal box. In case an earth terminal is required, a protrusion is provided on the motor frame.
- ❑ The drive end shaft is provided with a tapped hole according to DIN 332. Dimensions of the holes are shown in the table on page No. 3 of this catalogue.

SERIES : 14BG Frame Sizes 180 to 315

MEZ SAFE and SAVE types, 14BG series motors, in frames sizes 180 to 315, are three-phase squirrel-cage motors produced with standard enclosure protection of IP-55.

Rated voltage tolerance of ± 5% (Zone A) for motors is specified by IEC 38 standard. Additional tolerance of + 5% for rated voltage is valid according to EN 60 034.

Rated output refers to continuous duty S1 according to EN 60 034-1.

- ❑ Basic motor parts are made of cast iron, and both the cooling fans and fan covers are made of plastic.
- ❑ End shields are made of grey cast iron. Insulation of copper wires is Class F with temperature rise of Class B according to IEC 85.
- ❑ Motor feet are cast on to the frame body.
- ❑ Standard voltages are 380V D / 660V Δ, 50 Hz. Other voltages are available on request.

Output

Permissible output is to be specified for different working conditions like altitude and ambient temperature, according to the following tables.

Altitude abv. Sea level	Ambient Temperature		
	<30°C	30° to 40°C	45°C
1,000 m	1.07	1.00	0.96
1,500	1.04	0.97	0.93
2,000	1.00	0.94	0.90
2,500	0.96	0.90	0.86
3,000	0.92	0.86	0.82
3,500	0.88	0.82	0.79
4,000	0.82	0.77	0.74

Altitude abv. Sea level	Ambient Temperature		
	50°C	55°C	60°C
1,000 m	0.92	0.87	0.82
1,500	0.89	0.84	0.79
2,000	0.86	0.82	0.77
2,500	0.83	0.78	0.74
3,000	0.79	0.75	0.70
3,500	0.75	0.71	0.67
4,000	0.71	0.67	0.63

Output (kW)	Acceptable Output at 50Hz, kW	
	At 45°C	At 50°C
18.5	17.8	17
22	21	20
30	29	27.5
37	35.5	34
45	43	41.5
55	53	51
75	72	69
90	86	83
110	106	101
132	127	122
150	144	138
160	153	147
185	177	170
200	192	184



Strict testing and inspections on motor parts are carried out at many stages in various divisions of Siemens Elektromotory factories production to ensure first-class quality of the motors and that they comply to various standards set by Siemens' design engineers.

Rated Torque

The rated torque in Nm on the motor shaft is :

$$M = 9.55 \times P \times \frac{1000}{n}$$

where

P : Rated output in kW
n : Speed in rpm

Following diagrams show three typical torque characteristics only.

Torque characteristics

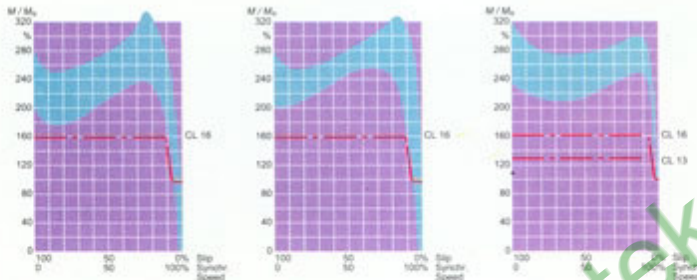

Terminal Boxes

Due to maximum permissible current, parallel terminal leads have to be used for connecting to earth terminal. Two parallel terminal leads are possible for terminal box of 1XB7 type. Two models of terminal boxes are available according to frame sizes, as shown in the photo below.



Type 1XB7 323 (for F225)



Type 1XB7 422 (for F225-F280)
1XB7 522 (for F315)

The protective earth conductor is connected by marked protective connecting terminals.

Earth terminal is placed at the external side of the motor frame.











Modern and high-tech equipment and facilities, including advanced electronic instrument, are used during production of MEZ motors to make sure that all parameters are within precise tolerances and accuracy.

Note :

- 1). Other electrical or mechanical executions such as special voltages, insulations, mounting, T-box position, etc, can be supplied on request.
- 2). General description, performance data, dimensions and other information for series 4AP, C, F, 3AFP and 16BA are also available on request.
- 3.) All above information and data are subject to change without any prior notice given to customers.

Other Range Of MEZ Motors ...

<p>SINGLE PHASE MOTORS</p>  <p>Frame Sizes : 63 to 100 Output Range : 0.18 to 2.2 kW</p>	<p>BRAKE MOTORS</p>  <p>Frame Sizes : 71 to 132 Output Range : 0.37 to 15 kW</p>	<p>SLIPRING MOTORS</p>  <p>Frame Sizes : 180 to 315 Output Range : 22 to 200 kW</p>	<p>FOOT & FLANGE MTD MOTORS</p>  <p>Frame Sizes : 63 to 355 Output Range : 0.18 to 400 kW</p>
<p>INCREASED SAFETY MOTORS</p>  <p>Frame Sizes : 63 to 355 Output Range : 0.18 to 400 kW Type of Protection : Eex e II</p>	<p>EXPLOSION PROOF MOTORS</p>  <p>Frame Sizes : 71 to 450 Output Range : 0.25 to 630 kW Type of Protection : Eex de IIC</p>	<p>LARGE FRAME SIZE MOTORS</p>  <p>Frame Sizes : 315 to 450 Output Range : 160 to 1000 kW Degree of Protection : IP55</p>	<p>COMBI MASTER (with inverters)</p>  <p>Frame Sizes : 56 to 132 Output Range : 0.12 to 7.5 kW Degree of Protection : IP55</p>